



Advanced Lithography 2018

EXHIBITION GUIDE

Exhibition

27-28 February 2018

Conferences + Courses

25 February-1 March 2018

San Jose Convention Center
San Jose, California, USA

www.spie.org/al

Moving technology to market™



ADVANCED LITHOGRAPHY 2018

TECHNOLOGIES FOR LITHOGRAPHY R&D, DEVICES, TOOLS,
FABRICATION, AND SERVICES.

Exhibition: 27-28 February 2018
Conferences + Courses: 25 February-1 March 2018
San Jose Convention Center · San Jose, California, USA

CUTTING-EDGE RESEARCH
WORLD-CLASS SPEAKERS
TRAINING AND EDUCATION
FOCUSED TECHNICAL TOPICS
50-COMPANY EXHIBITION

www.spie.org/AL

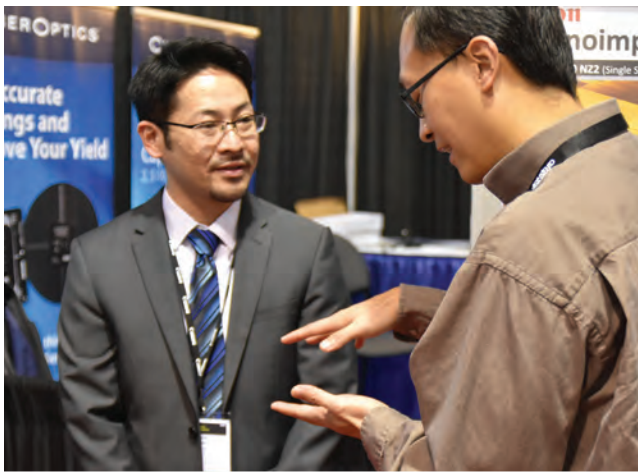

WELCOME TO THE EXHIBITION

SPIE. ADVANCED LITHOGRAPHY

Tuesday 27 February · 10:00 AM to 5:00 PM
 Wednesday 28 February · 10:00 AM to 4:00 PM

CONTENTS

Sponsors	2
Exhibition Floor Plan	3
Exhibitor Index	3
General Information	4
Course Daily Schedule	5
Exhibitor Directory	6-15
Product Categories	16-17
Policies	18-19
Corporate Members	20-23

SPIE would like to express its deepest appreciation to the symposium chairs, conference chairs, program committees, session chairs, and authors who have so generously given their time and advice to make this symposium possible.

The symposium, like our other conferences and activities, would not be possible without the dedicated contribution of our participants and members. This program is based on commitments received up to the time of publication and is subject to change without notice.

For information about exhibiting, sponsorship, and advertising opportunities at future Advanced Lithography events, contact: SPIE Sales at spiesales@spie.org

Sponsored by



Thanks to the following sponsors for their generous support of SPIE Advanced Lithography



SAN JOSE CONVENTION CENTER · EXHIBITION FLOOR

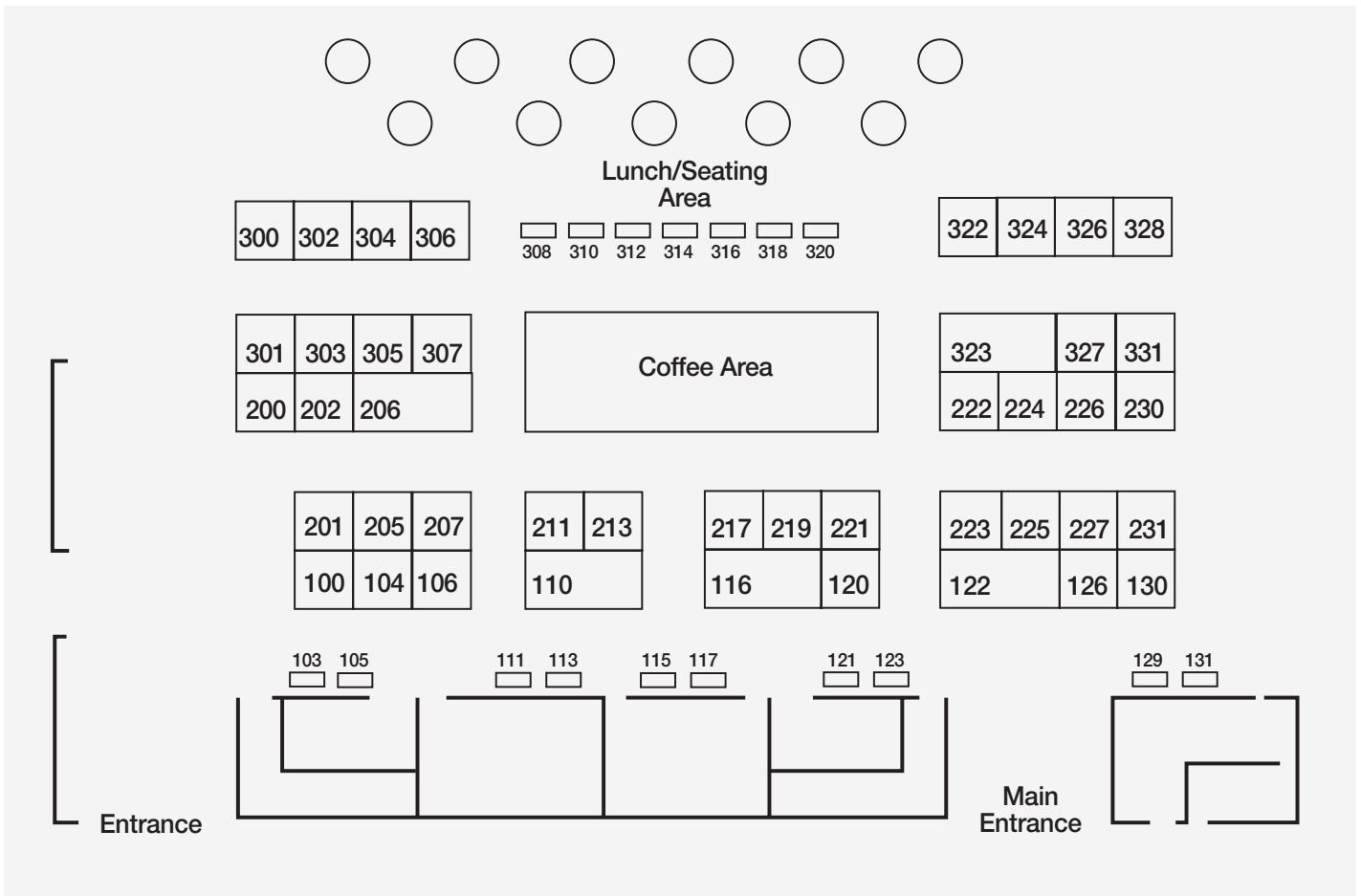

EXHIBITOR INDEX

Booth# Exhibitor	308 Energetiq Technology, Inc.	222 Mentor, a Siemens Business	100 Qoniac GmbH
213 Abeam Technologies, Inc.	304 Entegris, Inc.	201 Meyer Tool & Manufacturing, Inc.	226 Raith America, Inc.
310 amcross GmbH	322 GenISys Inc.	302 MGN International, Inc.	113 RASIRC
200 Amuneal Manufacturing Corp.	205 Gudeng Precision Industrial Co., Ltd.	224 Micro Lithography, Inc.	305 Rigaku Innovative Technologies, Inc.
207 attocube systems Inc.	227 Heidelberg Instruments Inc.	221 MicroChem Corp.	129 Sage Design Automation, Inc.
217 Benchmark Technologies	123 ibss Group, Inc.	103 Mitsui Chemicals America, Inc.	126 SCREEN SPE USA, LLC
110 Brewer Science, Inc.	316 INKO Industrial Corp.	303 Nanotronics	117 Seiwa Optical America Inc.
106 Cadence Design System, Inc	320 Inspectrology LLC	115 NTT Advanced Technology Corp.	116 Shin-Etsu MicroSi, Inc.
202 Canon U.S.A., Inc.	300 Integrated Micro Materials	120 Pall Corp.	105 Solid State Technology
219 Carl Zeiss SMT GmbH	231 J.A. Woollam Co.	225 PCAS	206 Synopsys, Inc.
104 Cosmotec, Inc.	306 JENOPTIK Optical Systems, LLC	312 POLLEN Metrology	121 TEL
323 Coventor, Inc.	130 JEOL USA Inc.	223 Pozzetta, Inc.	211 Vistec Electron Beam GmbH
314 CyberOptics Corp.	122 JSR Micro, Inc.		307 Zygo Corporation
111 DJ MicroLaminates, Inc.	324 KBTEM-OMO JSC		
	318 LouwersHanique		

GENERAL INFORMATION

Exhibition Hours

Tuesday 27 February · 10:00 am to 5:00 pm
Wednesday 28 February · 10:00 am to 4:00 pm

Registration

ONSITE REGISTRATION AND BADGE PICK-UP HOURS

San Jose Convention Center

Sunday 25 February · 7:15 am to 5:00 pm
Monday 26 February · 7:15 am to 4:00 pm
Tuesday 27 February · 7:30 am to 5:00 pm
Wednesday 28 February · 7:30 am to 4:00 pm
Thursday 1 March · 7:45 am to 4:00 pm
(Thursday is conference registration only)

Coffee Breaks

Served daily – 7:30 am, 10:00 am and 3:00 pm
Check individual conference listings for exact times and locations.
Sponsors:



Breakfast Breads

Convention Center, Ballroom Concourse
Monday – Thursday, 7:30 am

Sponsors:



Food and Refreshments for Purchase

Convention Center, Ballroom Concourse
Monday – Thursday, 7:30 am to 4:00 pm

Hot and cold snacks, hot entrees, deli sandwiches, salads, and pastries are available for purchase. Cash and credit cards accepted.

Exhibition Hall Concession Stand

Tuesday – Wednesday, 11:00 am to 2:00 pm

Hot and cold snacks, hot entrees, deli sandwiches, salads, and pastries are available for purchase. Cash and credit cards accepted.

SPIE Hosted Lunches

Exhibition Hall
Tuesday – Wednesday, 11:30 am to 1:00 pm

Complimentary tickets for these lunches will be included with full conference registrations. Students may purchase tickets at the Cashier Desk.

Desserts

Exhibition Hall 1 · Tuesday & Wednesday
Complimentary tickets for the dessert snacks will be included in conference attendee registration packets.

Internet Options

Wireless Access – Convention Center Upper Level Concourse
Complimentary wireless access is available; instructions will be posted onsite.

West end WiFi sponsored by



East end WiFi sponsored by



SPIE Conference and Exhibition App

Search and browse the program, special events, participants, exhibitors, courses, and more. Free Conference App available for iPhone and Android phones.

SPIE Bookstore

Convention Center Lobby near Registration

Stop by the SPIE Bookstore to browse the latest SPIE Press Books, proceedings, and educational materials. While there, get a t-shirt or educational toy to bring home to the family.

SPIE Education Services

Course Materials Pick-Up—located near SPIE Registration and open during registration hours

Sunday: Course Desk

Monday-Thursday: Bookstore

If you have registered to attend a course, please stop by the Course Materials Desk (Sunday) or Bookstore (Monday-Thursday) AFTER you pick up your badge. Turn in your course ticket to get your course materials and location of your course.

Browse course offerings and the other education services available: SPIE courses at conferences, online courses, DVDs, and customized in-company courses.

Advance your career.



- Learn from the best. This is your opportunity for direct instruction from legends in the semi/litho industry, many of whom are pioneers in their fields
- Course topics are aligned with current industry needs and trends
- Earn CEUs for professional continuing education requirements
- SPIE offers online courses and in-company training, www.spie.org/education

**· 14 ·
SPIE
COURSES**

SUNDAY

SC101 **Introduction to Microlithography: Theory, Materials, and Processing** (Willson, Bowden), 8:30 am to 5:30 pm, \$625 / \$735 / \$369

SC1099 **Chemistry and Lithography (Okoroanyanwu)**, 8:30 am to 5:30 pm, \$725 / \$835 / \$409

SC1100 **Scatterometry in Profile, Overlay and Focus Process Control (Cramer, Turovets)**, 1:30 pm to 5:30 pm, \$390 / \$445 / \$253

SC1132 **Computational Basis for Advanced Lithography Techniques (Lai)**, 8:30 am to 12:30 pm, \$390 / \$445 / \$253

SC1133 **Metrology Toolset Monitoring, Matching, Maintenance and Management (Solecky, Adan)** 8:30 am to 12:30 pm, \$390 / \$445 / \$253

SC1158 **Metrology of Image Placement (Starikov)**, 1:30 pm to 5:30 pm, \$395 / \$450 / \$255

SC1173 **How and Why: The big ideas in semiconductor lithography (Mack, Petersen)**, 8:30 am to 5:30, \$710 / \$820 / \$403

SC1209 **Data Analytics and Machine Learning in Semiconductor Manufacturing: Applications for Physical Design, Process and Yield Optimization (Cain, Capodiec)**, 1:30 pm to 5:30 pm, \$390 / \$445 / \$253

SC885 **Principles and Practical Implementation of Multiple Patterning (Dusa, Hsu)**, 8:30 am to 5:30 pm, \$625 / \$735 / \$369

SC888 **EUV Lithography (Bakshi, Ahn, Naulleau)**, 8:30 am to 5:30 pm, \$855 / \$965 / \$461

SC992 **Lithography Integration for Semiconductor FEOL & BEOL Fabrication (Lin, Zhang)**, 8:30 am to 5:30 pm, \$625 / \$735 / \$369

MONDAY

SC1030 **Interaction of Physical Design and Lithography (Yuan)**, 1:30 pm to 5:30 pm, \$390 / \$445 / \$253

TUESDAY

SC1187 **Understanding Design-Patterning Interactions for EUV and DSA (Gupta, Torres, Mallik)**, 1:30 pm to 5:30 pm, \$390 / \$445 / \$253

THURSDAY

SC616 **Practical Photoresist Processing (Dammel)**, 8:30 am to 12:30 pm, \$390 / \$445 / \$253

MONEY-BACK GUARANTEE

We are confident that once you experience an SPIE course for yourself you will look to us for your future education needs. However, if for any reason you are dissatisfied, we will gladly refund your money. We just ask that you tell us what you did not like; suggestions for improvement are always welcome.

CONTINUING EDUCATION UNITS



SPIE is accredited by the International Association for Continuing Education and Training (IACET) and is authorized to issue the IACET CEU.

SPIE Student members receive discounted course prices.

See full course descriptions and register for courses at the SPIE Cashier.

Course descriptions also available online. www.spie.org/ALCourses.

Price key: SPIE Member / Non-Member / SPIE Student Member

EXHIBITOR DIRECTORY



SPIE ADVANCED LITHOGRAPHY EXHIBITION

Tuesday · 10:00 am to 5:00 pm
Wednesday · 10:00 am to 4:00 pm

Exhibitors are listed in alphabetical order with details about products or services each is exhibiting. Companies are additionally cross-indexed by technology areas. The address of each exhibitor is also listed, making this Exhibition Guide an excellent reference tool to take back to your office and share with your colleagues.

Abeam Technologies, Inc. #213

22290 Foothill Blvd Ste 2, Hayward, CA, 94541 (USA)
+1 510 497 0222; fax +1 510 279 0076
support@abeamtech.com; www.abeamtech.com

Featured Product: myCD model based contours CDs and wall angles from SEM aSEM fast advanced simulator of SEM images

aBeam Technologies Inc. develops software to simulate and optimize e-beam technologies: CD-metrology, DI and EBL. myCD is a model based extraction of contours, CDs, LER, and SWA from SEM images. CHARIOT is the world's most advanced Monte Carlo software to simulate SEM and EBL. aSEM is a fast simulator of SEM images including charging, e-fields and detectors. qSEM is a software to monitor CD-SEM. Displace corrects placement error in EBL.

amcoss GmbH #310

Leusbundtweg 49a, Feldkirch, 6800 Austria
+43 5522 20950; fax +43 5522 209509
office@amcoss.com; www.amcoss.com

Featured Product: Supply and/or repair of filters, lenses and mirrors for Canon, Nikon, ASML and Ultratech equipment

amcoss GmbH is a small, innovative high-tech company with expert knowledge in wafer and substrate coating as well as in optics and mechatronics. amcoss designs and builds equipment for substrate coating (spin coaters) not only for standard, but also for complex, specialized applications. Furthermore, we design, manufacture and repair high-quality components, including refurbishment of special coatings for optics and mechatronics (photolithography, RTP, CVD, EPI, coating, metrology and plasma). Contact: David Erne, CEO, david.erne@amcoss.com; Jeffrey Wake, Sales, jeffwake@semisola.com

Amuneal Manufacturing Corp. #200

4737 Darrah St, Philadelphia, PA, 19124-2705 (USA)
+1 215 535 3000; fax +1 215 743 1715
info@amuneal.com; www.amuneal.com

Featured Product: Magnetic Shielding Design and Fabrication

Since 1965, Amuneal has been serving highly technical markets, working with leaders in aerospace, electronics, cryogenics, healthcare, and research to develop cost-effective magnetic shielding strategies and products that outperform the most demanding requirements. We offer a number of standard component shields to our clients, however, our culture and capabilities allow us to manufacture and install unique custom shields ranging from prototypes and models to full-scale assemblies. Contact: Michael Adolf, Director, Technical Products, mikea@amuneal.com; Stuart Koch, VP, Technical Products, stuartk@amuneal.com

attocube systems Inc. #207

SPIE Corporate Member
2020 Stuart St, Berkeley, CA, 94703 (USA)
510 649 9245
info@attocube.com; www.attocube.com

attocube is technology leader for high precision piezo positioning solutions, optical displacement sensors with picometer resolution and cryogenic measurement systems, all optimized for the use in extreme environmental conditions such as cryogenic temperatures, high magnetic fields and vacuum. The attoDRY800 cryo-optical table is the perfect platform for optical measurements at low temperatures and seamlessly integrates an ultra low vibration cold breadboard system into the optical table.

Benchmark Technologies #217

Bldg E, 7 Kimball Ln, Lynnfield, MA, 01940-2654 (USA)
+1 781 246 3303; fax +1 781 246 0308
contact@benchmarktech.com; www.benchmarktech.com

Featured Product: Grayscale Masks and Reticles, Lithography Monitoring Solutions

Benchmark is a leading supplier of test and setup reticles for lithography systems. The company also offers overlay software for in fab monitoring and analysis, general design and layout services, grayscale mask design, mask making services, imprint stamps and other custom fabrication services. Contact: Andrew Zanzal, VP Sales, azanzal@benchmarktech.com; Patrick Reynolds, President, preynolds@benchmarktech.com

SPONSOR

Brewer Science, Inc. #110

SPIE. Corporate Member

2401 Brewer Dr, Rolla, MO, 65401-7003 (USA)
+1 573 364 0300; fax +1 573 364 6880
info@brewerscience.com; www.brewerscience.com

Featured Product: Directed Self-Assembly, Multilayer Systems, ARC(R) Anti-reflective Coatings

Brewer Science is a global technology leader in developing and manufacturing innovative materials, and processes for the fabrication of semiconductors and microelectronic devices. Today, we continue to expand our technology portfolio to include products that enable advanced lithography, 3-D integration, chemical and mechanical device protection, nanotechnology, and thin wafer handling. Contact: Alex Smith, Director, Sales, asmith@brewerscience.com; Brent Scott, Senior Account Manager, bscott@brewerscience.com

Cadence Design System, Inc #106

2655 Seely Ave, San Jose, CA, 95134-1931 (USA)
+1 408 943 1234
events@cadence.com; www.cadence.com

Featured Product: Litho Physical Analyzer, Cadence CMP Predictor, Litho Electrical Analyzer, Cadence Pattern Analysis, LD

Cadence enables global electronic design innovation and plays an essential role in the creation of today's integrated circuits and electronics. Customers use Cadence software, hardware, IP, and services to design and verify advanced semiconductors, consumer electronics, networking and telecommunications equipment, and computer systems. In particular, Cadence® DFM solutions address both designer and manufacturer challenges resulting in improved design manufacturability and reduced time to yield. Contact: Philippe Hurat, Product Management Director, SSV, phurat@cadence.com

SPONSOR

Canon U.S.A., Inc. #202

SPIE. Corporate Member

Industrial Products Division, 3300 N First St, San Jose, CA, 95134-1900 (USA)
+1 408 468 2000
semi-info@cusa.canon.com; usa.canon.com/industrial

Featured Product: FPA-6300ES6a DUV Scanner

Canon USA Industrial Products Division provides advanced wafer & panel process equipment for applications including semiconductor, Advanced Packaging & display. Canon provides cost-effective wafer processing solutions including i-line & KrF optical lithography, nanoimprint lithography & Canon Anelva deposition equipment. Canon also has a variety of panel based lithography & deposition solutions that can be extended to a variety of applications. Contact semi-info@cusa.canon.com for more info. Contact: Doug Shelton, Marketing Manager, sshelton@cusa.canon.com

SPONSOR

Carl Zeiss SMT GmbH #219

Carl Zeiss Promenade 10, Jena, 07745 Germany
+49 3641 64 2563; fax +49 3641 64 2938
info.sms@zeiss.com; www.zeiss.com/mask-solutions

The ZEISS strategic business unit Semiconductor Metrology Systems (SMS) specializes in a key process in semiconductor manufacturing: the photomask. Core expertise in light and electron optics, complemented by a pioneering femto-second laser technology form the foundation of a product portfolio comprising in-die metrology, actinic qualification, repair, and tuning of photomasks. To increase automation and enhance tool capabilities, SMS also offers advanced software applications. Contact: Carl Zeiss SMT GmbH, Strategic Business Unit SMS, info.smt@zeiss.com

Cosmotec, Inc. #104

229 Polaris Ave Ste 3, Mountain View, CA, 94043-4579 (USA)
+1 408 428 9741; fax +1 408 428 9742
ask@cosmotec.us; www.cosmotec.us

Featured Product: UHV Feedthrough, Ultra Precision Parts, Aperture, Emitter, Filament, EDM, Wehnelt, Suppressor

The highest quality ceramic-to-metal over 25 Years of Excellence. Now in Silicon Valley. Quality: Highest quality components available. Leak-tested, inspected and quality assured. Our products come with a 1-year, 100% satisfaction guarantee. Custom Products: Perfection you can count on. Customized ceramic-to-metal components for your every need that will exceed your expectations. Delivery: Large inventory in Silicon Valley, make your business run smoothly. Contact: Taku Sekiguchi, President and CEO, sekiguchi@cosmotec.us

Coventor, Inc. #323

1000 Centre Green Way, Suite 200, Cary, NC, 27513 (USA)
+1 919 854 7500; fax +1 919 869 1472
sales@coventor.com; www.coventor.com

Featured Product: SEMulator3D, a 3D semiconductor virtual fabrication and process modeling platform

Coventor®, a Lam Research company, is a market leader in automated solutions for developing semiconductor process technology, as well as micro-electromechanical systems (MEMS). Coventor serves a worldwide customer base of integrated device manufacturers, memory suppliers, fabless design houses, independent foundries, and R&D organizations. Its SEMulator3D modeling and analysis platform is used for fast and accurate 'virtual fabrication' of advanced manufacturing processes. Contact: Dinesh Bettadapur, Director of Business Development, sales@coventor.com

CyberOptics Corp. #314

5900 Golden Hills Dr, Minneapolis, MN, 55416 (USA)
+1 763 542 5000; fax +1 763 542 5100
info@cyberoptics.com; www.cyberoptics.com

Featured Product: WaferSense® and ReticleSense® Measurement Portfolio including APS3, APSRQ and AMSR

CyberOptics Corporation is a leading global developer and manufacturer of high precision sensing technology solutions. CyberOptics sensors are being used in general purpose metrology and 3D scanning, surface mount technology (SMT) and semiconductor markets to significantly improve yields and productivity. Headquartered in Minneapolis, Minnesota, CyberOptics conducts worldwide operations through its facilities in North America, Asia and Europe. Contact: Allyn Jackson, Sales Manager & Sr. FAE, ajackson@cyberoptics.com



She's got it. Shouldn't you?

Sign up to the **free** weekly newsletter
and we'll send the news to you.

optics.org/newsletter

Get the latest industry news.



 follow us on twitter @opticsorg



optics.org

DJ MicroLaminates, Inc.

#111

490 Boston Post Rd, Sudbury, MA, 01776-3367 (USA)
+1 978 261 3188
info@djmicolaminates.com; www.djmicolaminates.com

Featured Product: Thick Epoxy Dry Film Resist Sheets

DJ MicroLaminates researches, develops and markets innovative dry film resist materials for MEMS, plating molds for metal microparts, polymer MEMS, multilayer microfluidics structures, BioMEMS, medical devices, wafer level packaging processes, and displays. We provide a ready-to-use epoxy based resin formulation coated between two throwaway carrier layers. Sheets or rolls with uniform thicknesses of 5µm to 1mm are quickly laminated to most substrates and are ready to expose within minutes.

Energetiq Technology, Inc.

#308

SPIE. Corporate Member

7 Constitution Way, Woburn, MA, 01801-1024 (USA)
+1 781 939 0763; fax +1 781 939 0769
info@energetiq.com; www.energetiq.com

Featured Product: Revolutionary Laser-Driven Light Sources

Energetiq Technology is the world's leading developer and manufacturer of ultra-bright broadband light sources for a wide variety of advanced applications in life and materials sciences, semiconductor manufacturing, and R&D. Energetiq's Laser-Driven Light Sources (LDLS) are based on a revolutionary technology that generates high brightness across the spectrum, with high reliability and long life. Contact: Karen Scammell, Vice President of Sales, kscammell@energetiq.com; Samuel Gunnell, Technical Sales Engineer, sgunnell@energetiq.com

Entegris, Inc.

#304

129 Concord Rd, Billerica, MA, 01821-4600 (USA)
+1 978 436 6500; fax +1 978 436 6735
www.entegris.com

Featured Product: Clean Chemical Delivery, Liquid Filtration and Purification, Advanced Wafer Handling

Look to us to reduce operating costs, maximize operational efficiency and improve the value of your chemical product. We offer a variety of liquid, air and liquid packaging, photochemical dispense pumps, gas filters and purifiers, reticle handling, and wafer process and shipper products in photolithography solutions.

GenlSys Inc.

#322

SPIE. Corporate Member

PO Box 410956, San Francisco, CA, 94141-0956 (USA)
+1 812 322 4554
info@genisys-gmbh.com; www.genisys-gmbh.com/

Featured Product: LAB All-in-One Lithography Simulation. Enable next generation products and faster development cycles

Based in Munich, Germany, with offices in Tokyo, Japan and San Francisco, California, GenlSys develops, markets and supports flexible, high-performance software solutions for the optimization of micro and nano fabrication processes. Addressing the market for lithography and inspection, GenlSys combines deep technical expertise in layout data processing, process modeling, correction and optimization with world class software engineering and a strong focus on ease of use. Contact: Roger McCay, Director of Sales North America, mccay@genisys-gmbh.com; Nezhil Unal, Vice President, unal@genisys-gmbh.com

Gudeng Precision Industrial Co., Ltd.

#205

9F. No 2 Sec 4 Jhongyang Rd, Tucheng Dist., New Taipei City, 23678 Taiwan
+886 2 2268 9141; fax +886 2 2269 1943
sales@gudeng.com; www.gudeng.com

Featured Product: Extreme Ultraviolet (EUV) Reticle Pod

Gudeng's mask and wafer handling solutions already have high market share internationally and become main source for many leading companies. Our trusted sales achievement could assure you 1. High quality products with ESD, ultra-low outgassing and particle-free protection 2. competitive market price to save your budget 3. exceptional customer service Visit our website for further understanding about the full range of our products: <http://www.gudeng.com/index.php/en/>. Contact: Ellen Wu, Product Assistant Manager, ellen.wu@gudeng.com; Kevin Su, International Sales Executive, kevin.su@gudeng.com

Heidelberg Instruments Inc.

#227

SPIE. Corporate Member

2807 Oregon Ct Ste E2, Torrance, CA, 90503-2635 (USA)
+1 310 212 5071; fax +1 310 212 5254
info@himt.us; www.himt.us

Featured Product: uPG 101, MLA100, MLA150, DWL 66+, DWL 2000/4000, VPG+ 200/400, VPG+ 800/1100/1400

Heidelberg Instruments Mikrotechnik GmbH is the world leader in the production of high precision photolithography systems and Maskless Aligners. Heidelberg Instruments has an installation base of over 800 systems in more than 50 countries. Our optical direct write lithography systems are installed in academic and industrial sites and are used in research, development and production. Applications Include Photomask Manufacturing, MEMS, MOEMS, Micro-fluidics, CMOS, LED and Display Technologies. Contact: Niels Wijnaendts van Resandt, Director of Sales - North and South America, nie@himt.us; Gregg Moore, Technical Sales Engineer - North and South America, gm@himt.us

ibss Group, Inc.

#123

SPIE. Corporate Member

111 Anza Blvd Ste 110, Burlingame, CA, 94010 (USA)
+1 650 513 1488; fax +1 650 513 1884
admin@ibssgroup.com; www.ibssgroup.com

Featured Product: GV10x DS Asher & Mobile Cubic DS Asher - effective in & ex situ hydrocarbon contamination removal.

Develops and produces GV10x downstream plasma cleaner models and related products used successfully in EM and Synchrotron labs around the world. The GV10x Downstream Asher reduces carbon & hydrocarbon contamination 10 to 20x more effectively than traditional methods at vacuum pressure safe for TMP operation. The MCA is a portable downstream plasma center for ex-situ specimen cleaning and in-situ e-beam chamber cleaning. Contact: Andrew Villegas, Marketing Communications, andrew.villegas@ibssgroup.com

SPIE Education

“The instructor was skilled and clear in his presentation. In contrast to some other courses I have taken there is value in using the higher definition of the videos where the video is available as the presenter actually gestures and contributes to the presentation.”

– Online course taker on Mounting of Optical Components



SPIE COURSES

Quality content. Expert instructors. accredited provider of IACET CEU.

Choose from a variety of options that work best for you.

- Courses at events
- In-company training—customized content at your facility.
- Online courses

Learn from the best. Solve problems. Get ahead.



For more information, visit:
www.spie.org/courses



SPIE is accredited by the International Association for Continuing Education and Training (IACET) and is authorized to issue the IACET CEU

INKO Industrial Corp.

#316

695 Vaqueros Ave, Sunnyvale, CA, 94085-3524 (USA)
+1 408 830 1040; fax +1 408 830 1058
sales@pellicle-inko.com; www.pellicle-inko.com

Featured Product: Pellicle, KrF pellicle, ArF pellicle

INKO, a U.S. based company, manufactures a complete line of pellicles for applications ranging from ASIC production to high volume memory production. From 248nm/193nm DUV lithography to I/G line lithography, we have the right pellicles for your needs. Contact: Joe Mac, Customer Service Manager, joemac@pellicle-inko.com; Feng Ye, QA Manager, ye@pellicle-inko.com

Inspectrology LLC

#320

SPIE Corporate Member

142 North Rd Ste N, Sudbury, MA, 01776 (USA)
+1 978 212 3100; fax +1 978 610 2622

info@inspectrology.com; www.inspectrology.com

Featured Product: IVS 200 CD and Overlay Metrology System

Inspectrology's IVS Overlay and CD Metrology Systems have been the gold standard for reliability in fabs for over 35 years. With rock solid reliability, accuracy, repeatability, and reproducibility, the IVS product line has evolved into the premier system for 75mm-200mm fabs. Compound Semiconductors in particular have unique challenges that require a different approach. An approach that includes a high level of flexibility, capability, and customer service. Contact: Paul Knutrud, VP Marketing, pknutrud@inspectrology.com

Integrated Micro Materials

#300

8141 Gateway Dr Ste 240, Argyle, TX, 76226 (USA)
+1 940 228 2219; fax +1 940 228 2234

sales@imicromaterials.com; www.imicromaterials.com

Featured Product: Lithography materials, ancillary products, process chemicals

Providers of lithography materials, process chemicals, and micro manufacturing consulting services. Contact: Brad Williams, General Manager, bwilliams@imicromaterials.com; Ron Eakin, Business Development Manager, roneakin@imicromaterials.com

J.A. Woollam Co.

#231

645 M St Ste 102, Lincoln, NE, 68508-2243 (USA)
+1 402 477 7501; fax +1 402 477 8214

sales@jawaollam.com; www.jawaollam.com

For all your ellipsometry needs, from measuring your thin film sample to the installation and training of your very own ellipsometer, the J.A. Woollam Company is here for you every step of the way. We offer a wide variety of ellipsometers to help you characterize your thin films, covering spectral ranges from vacuum ultra-violet to far infrared. We have 30+ years of experience and offer unrivaled customer support. Contact us today to learn more about our products lineup at sales@jawaollam.com.

JENOPTIK Optical Systems, LLC #306

SPIE Corporate Member

16490 Innovation Dr, Jupiter, FL, 33478-6428 (USA)
+1 561 881 7400; fax +1 561 881 1947
sales@jenoptik-inc.com; www.jenoptik-inc.com

JENOPTIK Optical Systems delivers a unique range of custom optical solutions incorporating precision assemblies and wafer scale microoptics for DUV through infrared applications. In-house expertise in system design, modeling, test and fabrication of optics and microoptics enables Jenoptik to deliver cutting-edge solutions for your inspection and metrology OEM applications. We combine design and engineering with high volume manufacturing to deliver from facilities in the US, Germany and Asia. Contact: Ron Moore, Vice President, Sales and Marketing, ronald.moore@jenoptik-inc.com; Tamara Whittaker, Marketing and Communications Mgr, tamara.whittaker@jenoptik-inc.com

JEOL USA Inc.

#130

SPIE Corporate Member

11 Dearborn Rd, Peabody, MA, 01960-3823 (USA)
+1 978 535 5900; fax +1 978 536 2205
salesinfo@jeol.com; www.jeolusa.com

Featured Product: Advanced EBL Systems

JEOL has supplied a complete line of systems since its first Lithography system in 1967. JEOL is the world's top supplier of EBL systems. Our applications range from mask/reticle production for high-end devices and nano-lithography research to ultrafine, direct write exposures for communication devices. JEOL continuously pursues higher writing accuracy, and throughput, with easier operation. We offer unsurpassed technical reliability and service expertise. Contact: Zane Marek, E-BEAM Product MGR / Salesman, marek@jeol.com; Hitoshi Kato, Technical Sales Manager, hkato@jeol.com

JSR Micro, Inc.

#122

SPIE Corporate Member

1280 N Mathilda Ave, Sunnyvale, CA, 94089-1213 (USA)
+1 408 543 8800; fax +1 408 543 8996
marketing@jsrmicro.com; www.jsrmicro.com

Featured Product: Leading-edge photoresists, developers, packaging materials and specialty chemicals

JSR Micro, Inc. is an innovation partner to its customers manufacturing the industry's most innovative family of photoresists, developers, and specialty chemicals. JSR is also a leader in Advanced Cleans Technology and materials for packaging. Our unique THB series of negative tone resists and WPR series of dielectric materials are ideal for next generation packaging technologies that facilitate higher performance. Contact: Joe Ritter, Sales, jritter@jsrmicro.com; Rowland Wong, Sales, rwong@jsrmicro.com

KBTEM-OMO JSC

#324

SPIE Corporate Member

ALK Bldg, 2 Partizansky Ave., Minsk, 220033 Belarus
+375 17 223 7128; fax +375 17 226 1207
office@kbtem-omo.by; www.kb-omo.by

Featured Product: Laser Pattern Generator, Evap/Depo Mask Repair, Automatic Mask/Wafer Defects Inspection, Stepper

KBTEM-OMO performs R&D and manufacturing of special opto-mechanical process systems, inspection and measurement equipment used in back end and front end microelectronics manufacturing: single and multibeam optoelectronic laser pattern generators; wafer stepper; large-area stepper; mask aligner; laser-based mask repair tool; automatic mask & wafer inspection systems with high detection threshold; in-house OEM manufacturing of hi-precision optical and mechanical parts Contact: Syarhei Avakaw, Director, office@kbtem-omo.by; Volha Sych, Marketing Manager, mar@kbtem-omo.by

LouwersHanique

#318

Energieweg 3A, Hapert, 5527 AH Netherlands
+31 497 339 696; fax +31 497 386 372
info@louwershanique.com; www.louwershanique.com

Featured Product: Technical ceramic and glass assemblies including UHV electrical and fiber optic feedthroughs.

LouwersHanique specializes in thermal forming of glass and the processing of technical glass, quartz glass and technical ceramics (such as aluminum oxide, silicon carbide, silicon, and Macor). The company activities also include the bonding and [clean room] assembly of unique material combinations based on an extensive range of bonding and integration technologies. The primary company focus and strength lies with low-volume high-mix niche solutions for high-end semiconductor capital equipment. Contact: Carel van de Beek, Sales Manager, carel.van.de.beek@louwershanique.com; Paul Meyer, Sales Engineer, paul.meyer@louwershanique.com

SPONSOR

Mentor, a Siemens Business

#222

8005 SW Boeckman Rd, Wilsonville, OR, 97070-7777 (USA)
+1 503 685 7000; fax +1 503 685 1543
mentor@calibre.com; www.mentor.com

Featured Product: Calibre

The challenges of developing advanced lithography flows require a strong partner. With a complete design-to-manufacturing platform for Immersion Lithography, EUV and DSA, Mentor, a Siemens Business, is the ideal partner for semiconductor manufacturing success. We offer best-in-class technology, comprehensive solutions, development and production support, and continuous innovation. That is why more than 30 fabs choose Mentor as their partner. Get more info at www.mentor.com. Contact: Gandharv Bhatara, Product Marketing Manager - OPC, gandharv_bhatara@mentor.com

EXHIBITOR DIRECTORY

Meyer Tool & Manufacturing, Inc. #201

4601 W Southwest Hwy, Oak Lawn, IL, 60453-1822 (USA)
+1 708 425 9080; fax +1 708 425 2612
sales@mtm-inc.com; www.mtm-inc.com

Featured Product: Custom Vacuum Chambers, Pressure Vessels, Cryogenic Systems, and Process Vessels

Meyer Tool & Mfg. is a custom design and fabrication service provider specializing in high complexity prototype to production development of pressure, vacuum, and cryogenic systems. We have been servicing the particle industry for nearly 50 years. We apply the unique skills required to build one of a kind particle collider equipment to a wide variety of industries. Our hardware is in advanced research facilities around the world from telescope cryostats to semiconductor process chambers. Contact: Mike Tortorello, General Manager, m.tortorello@mtm-inc.com

MGN International, Inc. #302

41984 Rio Nedo Ste 200, Temecula, CA, 92590 (USA)
+1 951 719 2910; fax +1 951 719 2920
sales@mgnintl.com; www.mgnintl.com

Featured Product: RION KS-41B &KS-19F liquid particle counters enabling EUV solvent & photoresist measurement

MGN International is RION's exclusive partner in North America. Rion's liquid particle counting systems use highly reliable and technologically superior laser technology, photo-detectors, & flow cells that allow for higher detection efficiency than competitive models. All Rion systems are user friendly, versatile, and simple to operate for inline and batch modes, offering compatible options for all liquids including solvent and photoresist and a wide range of refractive indices as low as 0.03um. Contact: Mike Bender, VP Sales, mbender@mgnintl.com; Joe Chen, Sales Mgr, JChen@mgnintl.com

Micro Lithography, Inc. #224

1257 Elko Dr, Sunnyvale, CA, 94089-2211 (USA)
+1 408 747 1769; fax +1 408 747 1978
www.mliusa.com

MLI is featuring pellicles formulated to yield high rates of transmission and long lifetimes for UV exposure. Our complete line of pellicle films ranges from broadband, g-/i-line to DUV (KrF-248nm and ArF-193nm). MLI's DUV pellicles have the lowest outgassing materials available in the market today.

MicroChem Corp. #221

200 Flanders Rd, Westborough, MA, 01581-1040 (USA)
+1 617 965 5511; fax +1 617 965 5818
mcc@microchem.com; www.microchem.com

MicroChem Corp, a leading manufacturer of electronic materials for over 26 years, focuses on providing innovative chemicals solutions to the MEMS, microelectronic, and semiconductor markets. Along with our exclusive distribution partnership with Dow electronic materials, MicroChem specializes in photoimagable epoxy, eBeam and PMGI Bi-layer resists and a suite of ancillary lithography materials. MicroChem is a wholly owned subsidiary of Nippon Kayaku Co. Ltd., Tokyo, Japan.

Mitsui Chemicals America, Inc. #103

61 Metro Dr, San Jose, CA, 95110 (USA)
+1 408 487 2891; fax +1 408 453 0684
www.mitsuichemicals.com

Since 1986, Mitsui has been the industry leader in providing pellicles to the semiconductor industry. Mitsui's ISO 9001 certified full automated plant produces Mitsui Pellicle, which transmits more than 99% of exposed light with excellent uniformity and longevity. Mitsui Pellicle, manufactured by rigorous selection of all materials and with more than 30 years accumulated expertise of non-dust structure, contributes to maximum production yields by eliminating pellicle related particle generations. Contact: Yurie Mizuno, Asst. Sales Manager, y.mizuno@mitsuichem.com; Hiromi Tsuboi, Sales Manager, h.tsuboi@mitsuichem.com

Nanotronics #303

SPIE Corporate Member

2251 Front St Ste 109-111, Cuyahoga Falls, OH, 44221-2577 (USA)
+1 330 926 9809
sales@nanotronics.co; www.nanotronics.co

Featured Product: nSPEC®

Nanotronics designs and manufactures autonomous microscopes to fill gaps in and enhance existing inspection and process control equipment. nSpec® is used by many of the world's leading semiconductor and electronics manufacturers. nSpec® is powered by advanced computer vision, machine learning, and artificial intelligence software analyzers to deliver maximum value and capability at lower cost. Contact: Julio Coppo, Senior Sales Director, julio@nanotronics.co; Ed Sandke, Sales Director, esandke@nanotronics.co

NTT Advanced Technology Corp. #115

1950 University Ave Ste 600, East Palo Alto, CA, 94303-2250 (USA)
+1 408 392 4280; fax +1 408 573 7721
bizdevelop@ntt-at.com; www.ntt-at.com

NTT Advanced Technology Corporation (NTT-AT) delivers optical solutions for EUV lithography and related technologies including Multilayer mirrors, Nano-scale test patterns, Ultra-thin SiN/SiC membranes and Fresnel zone plates. These leading-edge custom design components are fabricated for R&D solutions of light sources, inspection systems, photo resist and other fields. NTT-AT's optics are corresponding to LPPs, SRs/XFELs, HHGs and soft x-ray lasers.

Pall Corp. #120

25 Harbor Park Dr, Port Washington, NY, 11050-4605 (USA)
+1 516 484 5400; fax +1 516 801 9711
microelectronics@pall.com; www.pall.com

Featured Product: Pall is introducing the latest retention and cleanliness improvements for our lithography filters.

Pall offers a complete line of filtration, purification and separation technologies for all lithography processes. These include advanced Nylon 6,6, High density polyethylene and PTFE media. Pall has demonstrated that our innovative filter technologies can significantly reduce defectivity, decrease filter start up time and improve overall cost of ownership. Find out how Pall can help you improve your lithography process. Contact: Glenn Dado, Product Marketing Manager, Glenn_Dado@pall.com; Michael Mesawich, VP Product Marketing, michael_mesawich@pall.com

SPONSOR

PCAS

#225

SPIE Corporate Member

725 Trotter, St-Jean-sur-Richelieu, QC, J3B8J8 Canada
+1 450 348 0901; fax +1 450 349 1528
contact@pcas.com; www.pcas.com

Featured Product: Taylor-made manufacturing of polymers and complexe molecules for Advanced Lithography.

PCAS is a technology-oriented fine chemical group serving global industrial customers since 1962. Our core expertise is the development and production of high quality materials (polymers and small molecules) for Life Sciences and Specialty Chemicals markets, such as Lubricant, Cosmetics and Electronics. Our customers within the Electronic industry use our products in Photolithography/Microelectronics (Resist, ARC, Additives) and Printed Electronics (OLED, OFET, OPV) applications. Contact: Francis Belanger, Global Electronic Market Manager, francis.belanger@pcascanada.com; Dominique Juillet, Product Manager, dominique.juillet@pcas.com

POLLEN Metrology

#312

9 rue Rocher du Lorzier, Moirans, 38430 France
+33 662537789
johann@pollen-metrology.com; www.pollen-metrology.com

Featured Product: PLATYPUS software platform

POLLEN Metrology is a premier supplier of smart process-control software to accelerate the manufacturing of high performing materials. We propose a full software infrastructure dedicated to smart factory for yield enhancement and defect tracking.

Our breakthrough software technology powered by machine learning and data fusion accelerate the development of new processes which include advanced materials. The applications are in semiconductor, powders and nanomaterials industries. Contact: Johann Foucher, CEO, johann@pollen-metrology.com

Pozzetta, Inc.

#223

3121 S Platte River Dr, Englewood, CO, 80110-2139 (USA)
+1 303 783 3172; fax +1 303 374 7342
sales@pozzetta.com; www.pozzetta.com

Featured Product: Photomask Boxes & Cassettes, SMIF Pods, Reticle Storage Solutions, Wafer Carriers, Fittings & Valves

We help our customers reduce costs with customized in-process solutions such as reticle boxes and reticle storage solutions, wafer carriers, and critical device shipping solutions. We help optimize fab space by personally reviewing the storage and processing of critical devices and delivering complete solutions that include asset tracking tags, reticle pods and custom cleanroom racks. We also help our customers manage maintenance programs for pods, cassettes, and high purity fluid applications. Contact: Artemis Vasiliades, Account Executive, artemis@pozzetta.com; Scott Reese, Account Executive, scott.reese@pozzetta.com

SPIE

MEMBERSHIP

A long-term investment that pays off



Join or Renew your SPIE Membership

1 year \$125 | 3 years \$350 | Lifetime \$995

Discounts for students and early career professionals

- Complimentary SPIE Journal of your choice
- Free online professional development courses
- 10 SPIE Digital Library downloads
- Discounts on events, publications, SPIE Digital Library, and courses
- Exclusive access to Member networking events
- Career advancement and peer recognition
- Complimentary *SPIE Professional* magazine

Your Resource. Your Society.

spie.org/membership

EXHIBITOR DIRECTORY

SPONSOR

Qoniac GmbH

#100

SPIE Corporate Member

Königsbrücker Str 34, Dresden, 01099 Germany
+49 351 4189 3340; fax +49 351 41893341
exhibition@qoniac.com; www.qoniac.com

Featured Product: The OVALiS Suite provides unprecedented improvements of on-product optimization.

Qoniac is the premier supplier of on-product process optimization and control solutions for leading-edge semiconductor lithography & patterning. Founded in 2009 in Dresden (Germany), Qoniac is a fast growing company with customers and representatives currently in the USA, Europe, Singapore, Taiwan, China, Korea and Japan. Our international team represents decades of experience in process optimization for lithography and patterning as well as international experience in software development.

Raith America, Inc.

#226

1377 Long Island Motor Parkway Ste 101, Islandia, NY, 11749 (USA)
+1 631 738 9500; fax +1 631 738 2055
sales@raithamerica.com; www.raith.com

Featured Product: Electron Beam Lithography, EBL, EBPG, FIB Nanofabrication, ChipScanner, Large Area SEM imaging, EBID

Raith is a leading precision technology manufacturer for electron beam lithography (EBL), focused ion beam (FIB) nanofabrication and precise, large area SEM imaging. With sub-5 nm patterning performance, our instruments are enabling researchers in both academic and industry environments to continuously advance their applications in applied nanotechnological research and areas of industry that use nanotechnology for product applications or produce components from compound semiconductors. Contact: Andre Linden, Sales Manager and Applications Scientist, andre.linden@raithamerica.com

RASIRC

#113

7815 Silverton Ave, San Diego, CA, 92126 (USA)
+1 858 259 1220; fax +1 858 259 0123
info@rasirc.com; www.rasirc.com

Featured Product: H2O2 Delivery Systems for High Throughput ALD & Cleaning: Multiple Patterning & Residue Removal

RASIRC specializes in products that generate & deliver gas to fabrication processes. Each unit is a dynamic gas plant in a box—converting common liquid chemistries into safe & reliable gas flow for most processes. First to generate ultra-high purity (UHP) steam from de-ionized water, RASIRC technology can now also deliver hydrogen peroxide gas & hydrazine gas in controlled, repeatable concentrations. RASIRC gas delivery systems are critical for low temperature ALD, barrier layers & passivation. Contact: Lisa Collins-Sheffield, Account Executive, lcollinssheffield@rasirc.com; Dan Alvarez, Chief Technology Officer, dalvarez@rasirc.com

Rigaku Innovative Technologies, Inc.

#305

SPIE Corporate Member

1900 Taylor Rd, Auburn Hills, MI, 48326-1740 (USA)
+1 248 232 6400; fax +1 248 232 5000
optics@rigaku.com; www.RigakuOptics.com

Featured Product: MaxEuv High Efficiency Multilayer Optics and Optical systems for 13.5 nm, 6.x nm, and XUV

Rigaku Innovative Technologies (RIT) is a global supplier of high performance thin film coatings and optics used in commercial and academic institutions and government research facilities. RIT's state of the art coating facility and dedicated metrology equipment ensures the highest quality. RIT utilizes its staff of 10 PhD Scientists and 10 Engineers with over 250 years combined experience to provide the customer with the best solution to their coating and optics needs. Contact: Alex Sedlacek, Sales Engineer, alex.sedlacek@rigaku.com; Nick Grupido, VP Sales and Marketing, nick.grupido@rigaku.com

Sage Design Automation, Inc.

#129

SPIE Corporate Member

2075 de La Cruz Blvd Ste 105, Santa Clara, CA, 95050-3035 (USA)
+1 408 727 6294; fax +1 508 727 6288
info@sage-da.com; www.sage-da.com

Featured Product: iDRM: Software platform for design-process-technology co-development and co-optimization

iDRM from Sage-DA is a unique software platform that enables technologists to quickly capture design rules, analyze interactions and explore tradeoffs between technology and design constraints. With iDRM you can develop a complete design rule manual and automatically generate a full DRC runset. iDRM also automatically generates a correct-by-construction set of test layouts for systematic coverage of DRC runsets. The platform also provides pattern extraction, classification and characterization. Contact: Coby Zelnik, President, c.zelnik@sage-da.com; Kristen Frederick, Office Manager, k.frederick@sage-da.com

SPONSOR

SCREEN SPE USA, LLC

#126

820 Kifer Rd Ste B, Sunnyvale, CA, 94086-5214 (USA)
+1 408 523 9140; fax +1 408 523 9150
inquiries@screen-spe.com; www.screen.co.jp/eng/spe

Featured Product: SOKUDO DUO (DT-3000) lithography resist coat / develop, spin-on coat films and DSA track systems

SCREEN SPE USA, LLC is a subsidiary of SCREEN Semiconductor Solutions Co., Ltd., Kyoto, Japan; a manufacturer of semiconductor production equipment such as wafer cleaning, scrubbers, lithography coat/develop track equipment and flash/laser anneals is among the world's top 10 semiconductor equipment suppliers.

Fight Bias, Embrace Diversity



SPIE seeks to cultivate a culture of openness and inclusivity. Help us eradicate bias and make the world of optics and photonics a shining example of all minds coming together to innovate regardless of gender, race, nationality, culture, educational background, politics, sexuality, body-type and age, for the betterment of life.

Educate yourself on the issues faced by a diverse workforce, challenge your own assumptions, and tap into the rich pool of talent, perspectives, and ideas offered by people different from you.

SPIE. DIVERSITY+ INCLUSION

Seiwa Optical America Inc. #117

SPIE Corporate Member

3042 Scott Boulevard, Santa Clara, CA, 95054 (USA)
+1 408 844 8008; fax +1 408 844 8944
info@seiwaamerica.com; www.seiwaamerica.com

Featured Product: 1:1 Projection Exposure System

For over 50 years, SEIWA OPTICAL has been a provider of standard and customizable optical solutions for machine vision, inspection, and industrial processing. We have offices established worldwide and are also a distributor for industrial vision products. Contact: info@seiwaamerica.com

Shin-Etsu MicroSi, Inc. #116

SPIE Corporate Member

10028 S 51st St, Phoenix, AZ, 85044-5203 (USA)
+1 480 893 8898; fax +1 480 893 8637
info@microsi.com; www.microsi.com

Featured Product: photomask blanks, EB resists, pellicles, synthetic quartz, advanced resists

Shin-Etsu, the world's No. 1 supplier of semiconductor silicon wafers and a leading supplier of essential electronic materials. Shin-Etsu's product portfolio includes, photomask blanks, EB resists, pellicles, synthetic quartz, semiconductor advanced resists along with numerous specialized thermal interface materials. Contact: Edwin Nichols, Marketing Manager, enichols@microsi.com

SPONSOR

Solid State Technology #105

1786 18th St, San Francisco, CA, 94107-2343 (USA)
+1 415 255 0390; fax +1 415 255 9214
info@extensionmedia.com; solid-state.com

Solid State Technology reaches the largest, most qualified community of decision makers for semiconductor and electronics manufacturing through the magazine, email newsletters, website, webcasts and The ConFab Conference & Networking event. Topics include Advanced Packaging, MEMS, LEDs and Displays as well as current trends in the industry. Visit us here www.solid-state.com Contact: Kerry Hoffman, Director of Sales, info@extensionmedia.com

Synopsys, Inc. #206

SPIE Corporate Member

690 E Middlefield Rd, Mountain View, CA, 94043-4010 (USA)
+1 650 584 5000; fax +1 650 584 4102
info@synopsys.com; www.synopsys.com

Featured Product: DTCO, Proteus ILT, Proteus LRC, CATS, Sentaurus Lithography

Synopsys provides industry-proven EDA solutions to meet the demands of today's advanced IC manufacturing processes while setting the standard in platform flexibility to enable innovative solutions for next generation technology nodes. Synopsys comprehensive Mask Synthesis, Mask Data Preparation, TCAD and Yield Management tools provide leading-edge performance, accuracy, quality, and cost of ownership for all your production and development needs.

SPONSOR

TEL #121

2400 Grove Blvd, Austin, TX, 78741-6500 (USA)
+1 512 424 1152
www.tel.com

As a leading global company of semiconductor and flat panel display (FPD) production equipment, Tokyo Electron Limited (TEL) engages in development, manufacturing, and sales in a wide range of product fields. All of TEL's semiconductor and FPD production equipment product lines maintain high market shares in their respective global segments. TEL provides outstanding products and services to customers through a global network of approximately 75 locations in 16 countries in the U.S., Europe, and Asia. <http://www.tel.com> Contact: Katy Crist, marketing@us.tel.com

Vistec Electron Beam GmbH #211

Ilmstr 4, Jena, 07743 Germany
+49 3641 799 80; fax +49 3641 7998 222
electron-beam@vistec-semi.com; www.vistec-semi.com

Featured Product: Vistec SB250 series & Vistec SB3050 series Variable Shaped Beam Lithography

Vistec Electron Beam GmbH provides leading technology solutions for advanced electron-beam lithography. Based on the Variable Shaped Beam (VSB) principle, the electron-beam lithography systems are mainly utilized for semiconductor applications and advanced research as silicon direct write, compound semiconductor, mask making as well as integrated optics and several new emerging markets. The company is located in Jena, Germany and maintains service & support centers in Europe, Taiwan & in the US. Contact: Ines Stolberg, Manager Product Management & Marketing, ines.stolberg@vistec-semi.com; Kevin Grens, Business Development Manager

Zygo Corporation #307

SPIE Corporate Member

21 Laurel Brook Rd, Middlefield, CT, 06455-1291 (USA)
+1 860 347 8506; fax +1 860 347 8372
inquire@zygo.com; www.zygo.com

Zygo Corporation is a customer-focused technology leader well known for developing yield-enhancement solutions for precision manufacturing industries. Zygo Corporation's solutions employ process measuring instruments, automation technology, and precision optical components and assemblies to benefit a wide variety of industries including aerospace, defense, semiconductor capital equipment and components, automotive, optical, and R&D. Contact: Kurt Redlitz, Vice President, kredlitz@zygo.com; Michael Cumbo, Vice President, mcumbo@zygo.com

PRODUCT CATEGORIES

ASTRONOMY

Cosmotec, Inc.
Meyer Tool & Manufacturing, Inc.
Rigaku Innovative Technologies, Inc.
XEI Scientific, Inc.

BASIC RESEARCH, SCIENCE

attocube systems Inc.
Coventor, Inc.
Gudeng Precision Industrial Co., Ltd.
NTT Advanced Technology Corp.
POLLEN Metrology
Raith America, Inc.
Rigaku Innovative Technologies, Inc.
Synopsys, Inc.
Vistec Electron Beam GmbH
XEI Scientific, Inc.

BIOMEDICAL, MEDICAL IMAGING, HEALTH CARE

attocube systems Inc.
LouwersHanique
NTT Advanced Technology Corp.
Seiwa Optical America Inc.

CAMERAS AND IMAGING SYSTEMS

Canon U.S.A., Inc.
Inspectrology LLC
Rigaku Innovative Technologies, Inc.
Seiwa Optical America Inc.

CHEMICAL AND BIOLOGICAL ANALYSIS

LouwersHanique
NTT Advanced Technology Corp.
Rigaku Innovative Technologies, Inc.
XEI Scientific, Inc.

COMMUNICATIONS & NETWORKING

Cadence Design System, Inc

COMPUTING SYSTEMS, DATA PROCESSING

attocube systems Inc.
Cadence Design System, Inc
LouwersHanique
POLLEN Metrology
Raith America, Inc.

COMPUTING, DATA PROCESSING HARDWARE

Cadence Design System, Inc

CONSULTING SERVICES

amcoss GmbH
Benchmark Technologies
Coventor, Inc.
Synopsys, Inc.

CONSUMER ELECTRONICS

Cadence Design System, Inc

DEFENSE, SECURITY, LAW ENFORCEMENT

Raith America, Inc.

DETECTORS, SENSORS

Canon U.S.A., Inc.
CyberOptics Corp.

DISPLAYS

Gudeng Precision Industrial Co., Ltd.

DISPLAYS: CONSUMER, INFORMATION, ENTERTAINMENT

Canon U.S.A., Inc.
Raith America, Inc.
Seiwa Optical America Inc.

DISTRIBUTOR, RESELLER, INTEGRATOR

Seiwa Optical America Inc.

EARTH SCIENCES, ENVIRONMENTAL MONITORING, CLIMATE

XEI Scientific, Inc.

EDUCATION AND TRAINING

Coventor, Inc.

ELECTRONIC COMPONENTS

LouwersHanique

ELECTRONIC, DIGITAL IMAGING

KBTEM-OMO JSC
POLLEN Metrology

EMERGING PHOTONICS TECHNOLOGIES

Coventor, Inc.

FIBER OPTICS AND ACCESSORIES

LouwersHanique

INDUSTRIAL SENSING AND MEASUREMENT

attocube systems Inc.
Canon U.S.A., Inc.
POLLEN Metrology
XEI Scientific, Inc.

LASER COMPONENTS AND ACCESSORIES

LouwersHanique
NTT Advanced Technology Corp.
Shin-Etsu MicroSi, Inc.

LASER INDUSTRY

Meyer Tool & Manufacturing, Inc.
NTT Advanced Technology Corp.

LASERS AND SYSTEMS

NTT Advanced Technology Corp.

LED, OLED, NON-LASER LIGHT SOURCES

Seiwa Optical America Inc.



International Day of Light

16 May

Following the highly successful International Year of Light and Light-based Technologies 2015, The International Day of Light was proclaimed at the General Conference of UNESCO in November 2017 and the first celebration will take place on 16 May 2018.

The broad theme of light will allow many different sectors of society around the world to participate in activities every 16 May to raise awareness of science and technology, art and culture, and their importance in achieving the goals of UNESCO — education, equality and peace.

SPIE supports the International Day of Light to promote awareness of life-saving, life-enhancing light.

SPIE IDL GRANTS • FREE IDL MATERIALS • SPIE PHOTO CONTEST

For more information: www.spie.org/IDL



SPIE.

PRODUCT CATEGORIES

LITHOGRAPHIC EQUIPMENT

Abeam Technologies, Inc.
amcoss GmbH
Benchmark Technologies
Canon U.S.A., Inc.
Cosmotec, Inc.
Coventor, Inc.
Gudeng Precision Industrial Co., Ltd.
JEOL USA Inc.
KBTEM-OMO JSC
LouwersHanique
MGN International, Inc.
Raith America, Inc.
Rigaku Innovative Technologies, Inc.
SCREEN SPE USA, LLC
Vistec Electron Beam GmbH

MACHINE VISION, FACTORY AUTOMATION

Canon U.S.A., Inc.
Gudeng Precision Industrial Co., Ltd.
Seiwa Optical America Inc.

MATERIALS PROCESSING, LASERS IN MANUFACTURING

attocube systems Inc.
LouwersHanique
NTT Advanced Technology Corp.

MATERIALS, ABRASIVES, CHEMICALS

Brewer Science, Inc.
Gudeng Precision Industrial Co., Ltd.
JSR Micro, Inc.
NTT Advanced Technology Corp.
PCAS
POLLEN Metrology
RASIRC
Shin-Etsu MicroSi, Inc.

MICROSCOPES

Abeam Technologies, Inc.
attocube systems Inc.
FRT of America, LLC
Inspectrology LLC
JEOL USA Inc.
KBTEM-OMO JSC
NTT Advanced Technology Corp.
Raith America, Inc.
Seiwa Optical America Inc.
XEI Scientific, Inc.

MICROTECHNOLOGY

Brewer Science, Inc.
Gudeng Precision Industrial Co., Ltd.
POLLEN Metrology
Vistec Electron Beam GmbH

MISC CONSUMABLES AND EQUIPMENT

Gudeng Precision Industrial Co., Ltd.
JEOL USA Inc.
MGN International, Inc.
XEI Scientific, Inc.

NANOTECHNOLOGY PRODUCTS

Abeam Technologies, Inc.
Meyer Tool & Manufacturing, Inc.
POLLEN Metrology
Vistec Electron Beam GmbH
XEI Scientific, Inc.

OPTICAL COATINGS, THIN FILMS

amcoss GmbH
Brewer Science, Inc.
Meyer Tool & Manufacturing, Inc.
Rigaku Innovative Technologies, Inc.

OPTICAL COMPONENTS - FILTERS, MIRRORS, OTHER

amcoss GmbH
Benchmark Technologies
Canon U.S.A., Inc.
LouwersHanique
NTT Advanced Technology Corp.
Rigaku Innovative Technologies, Inc.
XEI Scientific, Inc.

OPTICAL COMPONENTS - LENSES

amcoss GmbH
KBTEM-OMO JSC
Rigaku Innovative Technologies, Inc.
Seiwa Optical America Inc.

OPTICAL DESIGN AND ENGINEERING

amcoss GmbH
Coventor, Inc.
Rigaku Innovative Technologies, Inc.
Vistec Electron Beam GmbH

OPTICAL FABRICATION EQUIPMENT

KBTEM-OMO JSC
Meyer Tool & Manufacturing, Inc.

OPTICS MANUFACTURING

amcoss GmbH
KBTEM-OMO JSC
LouwersHanique
Rigaku Innovative Technologies, Inc.
Seiwa Optical America Inc.

PHOTONIC INTEGRATION

Coventor, Inc.

POSITIONING EQUIPMENT, MOTION CONTROL AND ACCESSORIES

attocube systems Inc.
Raith America, Inc.

SEMICONDUCTOR DEFENSE SECURITY

Inspectrology LLC
Meyer Tool & Manufacturing, Inc.

SEMICONDUCTOR MANUFACTURING

Abeam Technologies, Inc.
Cadence Design System, Inc.
Canon U.S.A., Inc.
Cosmotec, Inc.
Coventor, Inc.
Entegris, Inc.
GenSys Inc.
Gudeng Precision Industrial Co., Ltd.
KBTEM-OMO JSC
POLLEN Metrology
Raith America, Inc.
SCREEN SPE USA, LLC
Seiwa Optical America Inc.
Synopsys, Inc.
Vistec Electron Beam GmbH

SOFTWARE

Abeam Technologies, Inc.
Benchmark Technologies
Coventor, Inc.
LouwersHanique
GenSys Inc.
JEOL USA Inc.
POLLEN Metrology
Synopsys, Inc.
Vistec Electron Beam GmbH

SOLAR & ALTERNATIVE ENERGY

Gudeng Precision Industrial Co., Ltd.
POLLEN Metrology

SPECTROSCOPY DEVICES AND EQUIPMENT

FRT of America, LLC
MGN International, Inc.

TEST AND MEASUREMENT, METROLOGY

Abeam Technologies, Inc.
attocube systems Inc.
CyberOptics Corp.
FRT of America, LLC
Inspectrology LLC
MGN International, Inc.
XEI Scientific, Inc.

VACUUM, COOLING, GAS HANDLING EQUIPMENT

attocube systems Inc.
Cosmotec, Inc.
Meyer Tool & Manufacturing, Inc.



LAND THE PERFECT JOB

SPIE. CAREER CENTER

WWW.SPIECAREERCENTER.ORG

SPIE EVENT POLICIES

Acceptance of Policies and Registration Conditions

The following Policies and Conditions apply to all SPIE Events. As a condition of registration, you will be required to acknowledge and accept the SPIE Registration Policies and Conditions contained herein.

Attendee Registration and Admission Policy

SPIE, or their officially designated event management, in their sole discretion, reserves the right to accept or decline an individual's registration for an event. Further, SPIE, or event management, reserves the right to prohibit entry or to remove any individual whether registered or not, be they attendees, exhibitors, representatives, or vendors, whose conduct is not in keeping with the character and purpose of the event. Without limiting the foregoing, SPIE and event management reserve the right to remove or refuse entry to anyone who has registered or gained access under false pretenses, provided false information, or for any other reason whatsoever that they deem is cause under the circumstances.

Payment Policy

Registrations must be fully paid before access to the conference is allowed. SPIE accepts VISA, MasterCard, American Express, Discover, Diner's Club, checks and wire transfers. Onsite registrations can also be paid with cash.

SPIE Safe Meeting and Misconduct Policy

SPIE is a professional, not-for-profit society committed to providing valuable and safe conference and exhibition experiences. SPIE is dedicated to equal opportunity and treatment for all its members, meeting attendees, staff, and contractors. Attendees are expected to be respectful to other attendees, SPIE staff, and contractors. Harassment and other misconduct will not be tolerated; violations will be addressed promptly and seriously. Consequences up to and including expulsion from the event as appropriate may be implemented immediately.

The SPIE anti-harassment policy can be found at <http://spie.org/policy>

Reporting of Unethical or Inappropriate Behavior

Onsite at an SPIE meeting, contact any SPIE Staff with concerns or questions for thorough follow-up. If you feel in immediate danger, please dial the local emergency number for police intervention.

SPIE has established a confidential reporting system for staff and all meetings participants to raise concerns about possible unethical or inappropriate behavior within our community. Complaints may be filed by phoning toll-free to +1-888-818-6898 from within the United States and Canada, or online at www.SPIE.ethicspoint.com and may be made anonymously.

Identification Requirement Policy

To verify registered participants and provide a measure of security, SPIE will ask attendees to present a government-issued photo identification at registration to collect registration materials.

Individuals are not allowed to pick up badges for other attendees. Further, attendees may not have some other person participate in their place at any conference-related activity. Such other individuals will be required to register on their own behalf to participate.

Access to Conference Events / Access for Children Younger than 18

All conference technical and networking events require a badge for admission. Registered attendees may bring children with them as long as they have been issued a badge. Registration badges for children under 18 are free and available at the SPIE registration desk onsite. Children under 14 years of age must be accompanied by an adult at all times, and guardians are asked to help maintain a professional, disturbance-free conference environment.

Exhibition Hall Access / Access for Children Younger than 18

Everyone who attends the exhibition must be registered and have a badge. Badges for children are free and available onsite at the registration desk. Children under 14 years of age must be accompanied by an adult at all times. Guardians are asked to help maintain a professional, disturbance-free exhibition environment. Children under 18 are not allowed in the exhibition area during exhibition move-in and move-out.

Unauthorized Solicitation Policy

Unauthorized solicitation in the Exhibition Hall is prohibited. Any nonexhibiting manufacturer or supplier observed to be distributing information or soliciting business in the aisles, or in another company's booth, will be asked to leave immediately.

SPIE EVENT POLICIES

Recording Policy

Conferences, courses, and poster sessions: For copyright reasons, recordings of any kind are prohibited without prior written consent of the presenter or instructor. Attendees may not capture or use materials presented in any meeting/course room or in course notes on display without written permission. Consent forms are available at Speaker Check-In or SPIE Registration. Individuals not complying with this policy will be asked to leave a given session and/or asked to surrender their recording media. Refusal to comply with such requests is grounds for expulsion from the event.

Exhibition Hall: Recordings of any kind are prohibited without explicit permission from on-site company representatives. Individuals not complying with this policy will be asked to surrender their recording media and to leave the exhibition hall. Refusal to comply with such requests is grounds for expulsion from the event.

Capture and Use of a Person's Image

By registering for an SPIE event, you grant full permission to SPIE to capture, store, use, and/or reproduce your image or likeness by any audio and/or visual recording technique and create derivative works of these images and recordings in any SPIE media now known or later developed, for any legitimate SPIE marketing or promotional purpose.

By registering for an SPIE event, you waive any right to inspect or approve the use of the images or recordings or of any written copy. You also waive any right to royalties or other compensation arising from or related to the use of the images, recordings, or materials. By registering, you release, defend, indemnify and hold harmless SPIE from and against any claims, damages or liability arising from or related to the use of the images, recordings or materials, including but not limited to claims of defamation, invasion of privacy, or rights of publicity or copyright infringement, or any misuse, distortion, blurring, alteration, optical illusion or use in composite form that may occur or be produced in taking, processing, reduction or production of the finished product, its publication or distribution.

Laser Pointer Safety Information/Policy

SPIE supplies tested and safety-approved laser pointers for all conference meeting rooms. For safety reasons, SPIE requests that presenters use provided laser pointers.

Use of a personal laser pointer represents the user's acceptance of liability for use of a non-SPIE-supplied laser pointer. If you choose to use your own laser pointer, it must be tested to ensure <5 mW power output. Laser pointers in Class II and IIIa (<5 mW) are eye safe if power output is correct, but output must be verified because manufacturer labeling may not match actual output. You are required to sign a waiver releasing SPIE of any liability for use of potentially non-safe, personal laser pointers. Waivers are available at Speaker Check-In.

Unsecured Items Policy

Personal belongings should not be left unattended in meeting rooms or public areas. Unattended items are subject to removal by security. SPIE is not responsible for items left unattended.

Wireless Internet Service Policy

At most events, SPIE provides wireless access for attendees. Properly secure your computer before accessing the public wireless network. SPIE is not responsible for computer viruses or other computer damage.

No-Smoking Policy

Smoking, including e-cigarettes, is not permitted at any SPIE event.

Agreement to Hold Harmless

Attendee agrees to release and hold harmless SPIE from any and all claims, demands, and causes of action arising out of or relating to your participation in the event you are registering to participate in and use of any associated facilities or hotels.

Event Cancellation Policy

If for some unforeseen reason SPIE should have to cancel an event, processed registration fees will be refunded to registrants. Registrants will be responsible for cancellation of travel arrangements or housing reservations and the applicable fees.

SPIE International Headquarters

PO Box 10
Bellingham, WA 98227-0010 USA
Tel: +1 360 676 3290
Fax: +1 360 647 1445
help@spie.org • www.SPIE.org

SPIE Europe Offices

2 Alexandra Gate
Ffordd Pengam, Cardiff, CF24 2SA UK
Tel: +44 29 2089 4747
Fax: +44 29 2089 4750
info@spieeurope.org • www.SPIE.org

SPIE CORPORATE MEMBERSHIP

SPIE Corporate Membership gives companies the best visibility in the industry, access to important information (the latest R&D updates, educational opportunities, and industry intelligence) and top talent.

SPIE, with more Corporate Members than any society or association in our field, is the definitive global business resource for the photonics industry and its members.

That's why SPIE is recognized as "best for industry"—and why joining is good for business.

Company Name	amp Cameras, LLC	Bühler Inc.	Covesion Ltd.
3DOptix	Andover Corp.	BWT Beijing Ltd.	CPG Optics, Inc.
3SAE Technologies, Inc.	Aperture Optical Sciences Inc.	Calmar Laser	CREOL, The College of Optics and Photonics, Univ. of Central Florida
4D Technology Corp.	Applied Image, Inc.	Cambridge Technology, A Novanta Co.	Cristal Laser S.A.
5N Plus Semiconductors, LLC	Applied Optics Ctr., a Div. of Optex Systems, Inc.	Canon U.S.A., Inc.	CryLight Photonics, Inc.
ABB Analytical Measurement	Applied Optics, Inc.	Canon U.S.A., Inc.	Cryslaser Inc.
Abet Technologies, Inc.	Applied Physics & Electronics, Inc.	Cascade Laser Corp.	CrystaLaser LC
Abrisa Technologies	Applied Surface Technologies	Cascade Optical Corp.	CRYSTECH Inc.
Access Laser Co.	Applied Technology Associates	CASTECH Inc.	Cyan Systems, Inc.
Acktar Ltd.	Àpre Instruments, LLC	CASTON Inc.	Cybel LLC
Adimec Electronic Imaging, Inc.	April Electro-Optics Co., Ltd.	CEA-LETI	Daheng New Epoch Technology, Inc.
Adlens Ltd	Archer OpTx, Inc.	Changchun New Industries Optoelectronics Technology Co., Ltd.	Daheng Optical Thin Film Ctr.
AdlOptica Optical Systems GmbH	Arden Photonics Ltd.	Chiral Photonics, Inc.	DataRay Inc.
Admesy B.V.	Arrow Thin Films, Inc.	Chroma Technology Corp.	DCM Tech, Corp.
AdTech Ceramics Co.	Arroyo Instruments, LLC	Chromacity Ltd.	Delphon Industries, LLC
AdTech Optics, Inc.	ASA Astrosysteme GmbH	Churchill Navigation	Deltron Crystal Industries, Inc.
AdValue Photonics, Inc.	Asahi Spectra USA Inc.	CI Systems, Inc.	Diamond USA Inc.
Advance Reproductions Corp.	Ascentta, Inc.	Cirrus Logic, Inc.	DIAS Infrared Corp.
Advanced Abrasives Corp.	asphericon GmbH	Clear Align	DiCon Fiberoptics, Inc.
Advanced Fiber Resources (Zhuhai) Ltd.	asphericon, Inc.	Coastal Connections	DILAS Diodenlaser GmbH
Advanced Microoptic Systems GmbH	A-Star Photonics, Inc.	Coherent Nufern	Diverse Optics Inc.
Advanced Opto-Mechanical Systems and Technologies Inc.	ASTRODESIGN, Inc.	Coherent, Inc.	Docter Optics, Inc.
Advanced Power Group Corp.	attocube systems Inc.	College of Optical Sciences, The Univ. of Arizona	Dominar, Inc.
Advanced Thin Films	Avantes, Inc.	Collimated Holes, Inc.	Dontech, Inc.
AdvR, Inc.	Avo Photonics, Inc.	Continuum	DRS Daylight Solutions
AEMtec GmbH	Ayase America Inc.	Contour Metrological & Manufacturing, Inc.	Dynamic Structures Ltd.
Aerotech, Inc.	B&W Tek	Contrast, Inc.	DynaVac
AFL	Ball Aerospace	CorActive High-Tech Inc.	E.R. Precision Optical Corp.
AKELA Laser Corp.	BaySpec, Inc.	Coresix Precision Glass, Inc.	Edmund Optics GmbH
Alazar Technologies, Inc.	Beamtech Optronics Co., Ltd.	Corning Advanced Optics	Edmund Optics Inc.
ALIO Industries Corp.	Beijing Scitlion Technology Co., Ltd.	Corning Communication Networks	Electro Optical Components, Inc.
Allied Vision Technologies Inc.	Berliner Glas KGaA Herbert Kubatz GmbH & Co.	Corning Display Glass	Electro-Optical Industries, Inc.
AllMotion, Inc.	BigC Dino-Lite Digital Microscope	Corning Environmental Technologies	Electro-Optics Technology, Inc.
Alluxa	Blue Ridge Optics, LLC	Corning Gorilla Glass	Elite Optoelectronics Co., Ltd.
ALPAO S.A.S.	Bodkin Design & Engineering, LLC	Corning Incorporated	Elliot Scientific Ltd.
Alpine Research Optics	Boston Applied Technologies, Inc.	Corning Incorporated	Emberion Oy
Altechna UAB	Boston Electronics Corp.	Corning Incorporated	EMD Performance Materials Corp.
Altos Photonics, Inc.	Boston Micromachines Corp.	Corning Life Sciences	EMF Corp.
American Photonics Co.	Boulder Nonlinear Systems	Corning Pharmaceutical Technologies	Empire Precision Plastics
AMETEK HCC Industries, Inc.	BoXin Photoelectric Co., Ltd.	Coventor, Inc.	Empire West, Inc.
AMETEK Precitech, Inc.	Brewer Science, Inc.		Energetiq Technology, Inc.
AMETEK Taylor Hobson Inc.	BRIDG		EoL
AMETEK, Inc.	Bristol Instruments, Inc.		EPIX, Inc.
	Brolis Semiconductors UAB		

SPIE CORPORATE MEMBERS

Evaporated Coatings, Inc.
EVERIX, Inc.
Exalos AG
Excelitas Technologies Corp.
Excell Technology
Feinwerkoptik Zünd AG
Fiber Optic Valley AB
Fiberguide Industries, Inc.
Fiberguide Industries, Inc.
Fibertech Optica Inc.
ficonTEC Service GmbH
First Light Imaging S.A.S.
First Sensor, Inc.
FISBA AG
Flexible Optical B.V.
FLIR Systems, Inc.
FluxData, Inc.
FOCtek Photonics, Inc.
Foreal Spectrum, Inc.
Fotofab, LLC
Frankfurt Laser Co.
Fraunhofer-Institut für Photonische
Mikrosysteme
Fresnel Technologies Inc.
Fuzhou Alpha Optics Co., Ltd.
Gel-Pak

General Dynamics-Global Imaging
Technologies
General Ruby & Sapphire Co.
GenSys Inc
Gentec Electro-Optics Inc.
German National Library of Science
and Technology (TIB)
Glass Fab, Inc.
Gooch & Housego PLC
Gooch & Housego, Boston
GPD Optoelectronics Corp.
Greenlight Optics, LLC
Grintech GmbH
GS Plastic Optics
Guangzhou CKLaser Co., Ltd.
Guernsey Coating Labs., Inc.
Gulf Fiberoptics, Inc.
Haas Laser Technologies, Inc.
Hangzhou Multi IR Technology Co.,
Ltd.
Haphit Inc
Hardin Optical Co.
HC Photonics Corp.
Headwall Photonics Inc.
Heidelberg Instruments Inc.
HEIDENHAIN Corp.

Hellma USA, Inc.
heracle GmbH
Heraeus Tenevo LLC
High Tech Rochester Inc.
HIGHYAG Lasertechnologie GmbH
Hinds Instruments, Inc.
Hindsight Imaging, Inc.
Hofstadter Analytical Services, LLC
HOLO/OR Ltd.
HOLOEYE Photonics AG
Holographix LLC
Hong Kong Productivity Council
HORIBA Instruments Inc.
HOYA Corp. USA
HTA Photomask
Huanic Corp.
HySpex
Ibsen Photonics A/S
ibss Group, Inc.
IDEX Health & Science LLC
IDEX Optical Technologies
II-VI EpiWorks, Inc.
II-VI Inc.
II-VI Infrared
II-VI Laser Enterprise
II-VI Marlow

II-VI Optical Systems
Imagine Optic Inc.
Imagine Optic SA
IMEC
IMPERX, Inc.
IMRA America, Inc.
Incom, Inc.
Indian Hills Community College
Infinite Optics Inc.
Infrared Materials, Inc.
Infrared Systems Development
Corp.
Infratec Infrared LLC
INGENERIC GmbH
Innolume GmbH
Innovations in Optics, Inc.
Innovative Photonic Solutions
INO
InPhenix, Inc.
Inrad Optics
Insight Photonic Solutions, Inc.
Inspectrology LLC
Institute for Photonics and
Advanced Sensing
Intlvac Thin Film
IntraAction Corp.

SPIE. PHOTOMASK
TECHNOLOGY +
EUV LITHOGRAPHY

17-20 September 2018
Monterey, California, USA
www.spie.org/puv2018

Call for Papers Photomask Technology + Extreme Ultraviolet Lithography 2018

The meeting for mask makers, EUVL, and emerging technologies.



Abstracts due 2 May 2018

SPIE CORPORATE MEMBERS

IO Industries, Inc.
IPG Photonics Corp.
IRCAM GmbH
IRD Glass
IRflex Corporation
Iris AO, Inc.
Irish Photonic Integration Ctr.
(IPIC)
IRnova AB
IRsweep AG
IRTronix, Inc.
Isomet Corp.
ISP Optics Corp.
Isuzu Glass, Inc.
ITF Technologies Inc.
JAYCO Cleaning Technologies
JenLab GmbH
JENOPTIK Optical Systems GmbH
JENOPTIK Optical Systems, LLC
JEOL USA Inc.
JSR Micro, Inc.
Kappa optronics, Inc.
Kapteyn-Murnane Labs., Inc.
Kaufman & Robinson, Inc.
KBTEM-OMO JSC
Ketek Corp.
Kigre, Inc.
Kiyohara Optics Inc.
KrellTech
Kugler of America Ltd.
Kupo Co. Ltd.
L-3 Cincinnati Electronics
Labsphere, Inc.
LaCroix Precision Optics
Lambda Research Corp.
Lambda Research Optics, Inc.
Lanmark Controls Inc.
Lasence Inc.
Laser Components USA, Inc.
Laser Focus World
Laser Institute of America
Laser Light Technologies Inc.
Laser-Femto
Laserline Inc.
Lasertel, Inc.
Laservision USA
LASORB
LASOS Lasertechnik GmbH
Lattice Electro Optics, Inc.
Leonardo DRS
LEONI Fiber Optics, Inc.
Lexington International, LLC
LightComm Technology Co., Ltd.
LightMachinery Inc.
LightPath Technologies, Inc.
Lightspace Technologies, SIA
LightTrans International UG
Liquid Instruments
Litron Lasers Ltd.
Lockheed Martin Aculight
LTI Optics, LLC
Lumencor, Inc.
Luminar Technologies, Inc.

Luna Optoelectronics
Luvantix SSCP
Luxel Corp.
Luxmex Technology Corp.
M Squared Lasers Ltd.
M3 Measurement Solutions
Mad City Labs., Inc.
Mahr
Marina Photonics, Inc.
Market Tech, Inc.
Marktech Optoelectronics
Marubeni America Corp.
Materion Precision Optics
Meadowlark Optics, Inc.
MegaWatt Lasers, Inc.
Metrology Concepts LLC
Metruie, Inc.
MH GoPower Company Limited
Micro Laser Systems, Inc.
MicroCircuit Laboratories, LLC
MICRONIX USA, LLC
Micronor Inc.
Microtech Instruments, Inc.
Mightex Systems
Mikro-Tasarim Elektronik San. ve
Tic. A.Ş.
Mildex, Inc.
Mindrum Precision, Inc.
Minus K Technology Inc.
Mirrorcle Technologies, Inc.
MKS Instruments, Inc.
ML Optic Corp.
MLD Technologies, LLC
Modulight USA, Inc.
Modulight, Inc.
MONTFORT Laser GmbH
MOXTEK, Inc.
MPA Crystal Corp.
MPB Communications Inc.
MWTechnologies, Lda
MY Polymers Ltd.
Naked Optics Corp.
NanoManyetik Bilimsel Cihazlar
San. ve Tic. Ltd. Sti.
nanoplus America Inc.
nanoplus Nanosystems and
Technologies GmbH
nanosystec GmbH
nanosystec GmbH - Asia Region
nanosystec Inc.
Nanotronics Imaging
National Aperture, Inc.
National Institute of Standards and
Technology
National Metrology Ctr.
National Scientific Optics, Inc.
Natsume Optical Corp.
Navitar Inc.
Necsel IP, Inc.
Necsel IP, Inc.
New England Optical Systems
New England Photoconductor
Corp.

New Scale Technologies, Inc.
New Source Technology, LLC
Newport Corp., a division of MKS
Instruments
nLIGHT, Inc.
Norland Products Inc.
NorPix, Inc.
Norsk Elektro Optikk AS
Northrop Grumman Cutting Edge
Optronics
NOVAE
NP Photonics, Inc.
nPoint, Inc.
NTFL
NuFlare Technology, Inc.
NuFlare Technology, Inc.
Nutfield Technology
Nüvü Caméras Inc.
Ocean Optics, Inc.
OEwaves, Inc.
OFS
Ohara Corp.
Ondax, Inc.
OPCO Lab., Inc.
Optec S.p.A.
Optical Engines, Inc.
Optical Filter Source, LLC
Optical Support, Inc.
Optics Balzers
Optics Technology, Inc.
Optics Valley
Optiforms, Inc.
OptiGrate Corp.
Optikos Corp.
Optilab LLC
Optimax Systems, Inc.
OptiPro Systems
OptiSource, LLC
Optiwave Systems Inc.
Opto Diode Corp.
Opto-Alignment Technology, Inc.
Optogama
Opto-Knowledge Systems, Inc.
Opto-Line International, Inc.
Optonetic LLC
Optores GmbH
OptoSigma Corp.
Optotune Switzerland AG
Optowaves, Inc.
optX Imaging Systems
OSELA Inc.
Oxxius SA
OZ Optics Ltd.
Pacific Laser Equipment
Pangolin Laser Systems, Inc.
Pantec Engineering AG
Pavilion Integration Corp.
PCAS Canada
PCO-TECH Inc.
Perkins Precision Developments,
LLC
PFG Precision Optics, Inc.

PHASICS Corp.
Photon Design
Photon Engineering LLC
Photon etc.
Photon Systems, Inc.
Photonic Cleaning Technologies
Photonics Finland
Photonics Industries International,
Inc.
Photonics Media/Laurin Publishing
PHOTONIS USA, Inc.
Photop Suwtech, Inc.
Photop Technologies, Inc.
PhotoSound Technologies, Inc.
PI (Physik Instrumente) L.P.
PicoQuant Photonics North
America, Inc.
PIEZOCONCEPT
piezosystem jena, Inc.
PIKE Technologies
PlaneWave Instruments, Inc.
Plasma-Therm LLC
Plastics International
Polaris Motion
Polish Holographic Systems
Povolzhskiy State Univ. of
Telecommunications and
Informatics
Precision Glass & Optics
Precision Glass Bending
Precision Optical
Princeton Infrared Technologies,
Inc.
Princeton Instruments
Princeton Lightwave, Inc.
Prior Scientific Inc.
Prizmatix Ltd.
PROMET Optics
Pure Photonics
PVP Advanced EO Systems, Inc.
Pyser-SGI Ltd.
QD Laser, Inc.
QED Technologies, Inc.
QPC Lasers Inc.
Quantel USA
Quartus Engineering Inc.
Raicol Crystals Ltd.
Rainbow Research Optics, Inc.
Raptor Photonics Ltd.
RAYLASE Laser Technology Inc.
Raytheon ELCAN Optical
Technologies
Redfern Integrated Optics (RIO)
Redondo Optics, Inc.
RedWave Labs Ltd.
Research Electro-Optics, Inc.
Reynard Corp.
RICOR USA, Inc.
Rigaku Innovative Technologies,
Inc.
Rochester Precision Optics, LLC
Rocky Mountain Instrument Co.
Rogers Germany GmbH

SPIE CORPORATE MEMBERS

Ross Optical Industries
RPC Photonics, Inc.
RPMC Lasers, Inc.
Rubicon Technology Inc.
Ruda-Cardinal, Inc.
Saber 1 Technologies
Sacher Lasertechnik GmbH
Safran Optics 1
Salem Distributing Co., Inc.
Santa Barbara Infrared, Inc.
Satisloh North America Inc.
Savvy Optics Corp.
SCANLAB America, Inc.
ScannerMAX
SCD Semiconductor Devices
SCD.USA Infrared, LLC
Schäfter + Kirchhoff GmbH
Schneider Optical Machines Inc.
Schneider Optics, Inc.
SCHOTT AG
SCHOTT DiamondView Armor
Products, LLC
SCHOTT North America, Inc.
SCHOTT North America, Inc.
scia Systems GmbH
Seattle Photonics Associates LLC
Seiwa Optical America Inc.
SemiNex Corp.
SensL Technologies Ltd.
Sensors Unlimited, a United
Technologies Co.
SensUp
Shanghai Optics Inc.
Shasta Crystals
Sheaumann Laser, Inc.
Shin-Etsu MicroSi, Inc.
Sierra Precision Optics
Sierra-Olympic Technologies, Inc.

Sigmadyne, Inc.
Sill Optics GmbH & Co. KG
Siskiyou Corporation
Si-Ware Systems
SlicingTech
SmarAct GmbH
SN&N Electronics, Inc.
Space Light Laboratory
Specim Spectral Imaging Ltd.
Spectral Devices Inc.
Spectral Instruments, Inc.
Spectrogon AB
Spectrogon UK Ltd.
Spectrogon US, Inc.
Spectrolight Inc.
Spectrum Scientific, Inc.
Spectrum Thin Films Corp.
Spica Technologies, Inc.
SRI International
Stanford Computer Optics, Inc.
StellarNet, Inc.
Sunny Opotech North America, Inc.
Sunny Technology
Sutter Instrument Corp.
Suzhou Jiujun Optics Co., Ltd.
Swamp Optics, LLC
Sydor Optics, Inc.
Synopsys, Inc.
Synopsys, Inc.
Syntec Optics
tec5USA, Inc.
Techmetals, Inc.
Technica Optical Components, LLC
Technical Manufacturing Corp.
TecOptics, Inc.
Tecport Optics, Inc.
Teledyne e2v UK Ltd.

Teledyne Judson Technologies
Telops Inc.
Tempo Clean Room Foam
Tempotec Optics Co., Ltd.
TeraXion Inc.
Texas Instruments Inc.
The Hong Kong Polytechnic Univ.
Thermo Fisher Scientific Inc.
Thorlabs, Inc.
TLC International World
Headquarters
TOPTICA Photonics, Inc.
Toshiba America Information
Systems, Inc.
Tower Optical Corp.
TRIOPTICS GmbH
TRUMPF Inc.
TRUMPF Inc.
TruTag Technologies, Inc.
TwinStar Optics, Coatings &
Crystals, Inc.
Tydex
ULTRA TEC Mfg., Inc.
UltraTape
Umicore Optical Materials USA, Inc.
United Lens Co., Inc.
Univ. of Rochester
Universal Photonics Inc.
UpTek Solutions Corp.
US Fiberoptic Technology, Inc.
Valtech Corp.
Vermont Photonics Technologies
Corp.
Vertilite Inc.
Viavi Solutions Inc.
Viavi Solutions Inc.
Video Scope International, Ltd.
Video Systems Srl

VisiMax Technologies, Inc.
Vision Components GmbH
Vision Research, Inc.
Vital Materials Co., Ltd.
Vixar Inc.
VM-TIM GmbH
Wasatch Photonics, Inc.
Wavelength Electronics, Inc.
Wavelength Opto-Electronic (S)
Pte. Ltd.
Webb Holdings LLC
WINHO Optical Mfg. Co., Ltd.
World Star Tech
Wuhan National Lab. for
Optoelectronics
WZW-Optic AG
Xactra Technologies
Xenics NV
Xenics USA, Inc.
XIMEA Corp.
Xonox Technology GmbH
XYALIS
Y&M Technologies, Inc.
Yenista Optics S.A.
YSL Photonics
Z & Z Optoelectronics Tech. Co.,
Ltd.
Zaber Technologies Inc.
Zarbeco, LLC
Zemax, LLC
Zeus Industrial Products, Inc.
Zurich Instruments AG
Zygo Corporation

PLAN YOUR WEEK

GET THE FREE SPIE CONFERENCE AND EXHIBITION APP

Find the best networking and information-gathering opportunities with this powerful planning tool. Schedule your time in the conferences...navigate the exhibition floor...make new connections.

Available for iOS and Android. Search: SPIE Conferences.

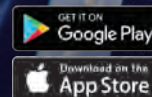

COURTESY OF
SPIE.

SPIE. AWARDS

SPIE is pleased to announce the 2018 winners of select SPIE Awards, honoring the best in optics and photonics for their significant achievements and contributions in advancing the science of light.



Paul Corkum
Gold Medal of the Society



Jim Grote
Directors' Award



Eugene Arthurs
President's Award



Sarath Gunapala
George W. Goddard Award



Sterling Backus
Harold E. Edgerton
Award



Tayyaba Hasan
Britton Chance Biomedical
Optics Award



Stephen Pompea
SPIE Educator Award



Paul Dapkus
Technology
Achievement Award



Karl Stetson
Chandra S. Vikram
Award in Optical
Metrology



Din Ping Tsai
Mozi Award



Laura Waller
Early Career
Achievement Award -
Academia

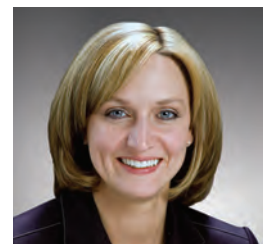

Misty Blowers
Early Career
Achievement Award -
Industry



Elizabeth Hillman
Biophotonics Technology
Innovator Award



Tom Baur
G.G. Stokes Award



Kishan Dholakia
Dennis Gabor Award



Philip Rogers
A.E. Conrady Award

Nominate a colleague today! See www.spie.org/awards.

SPIE. DIGITAL LIBRARY

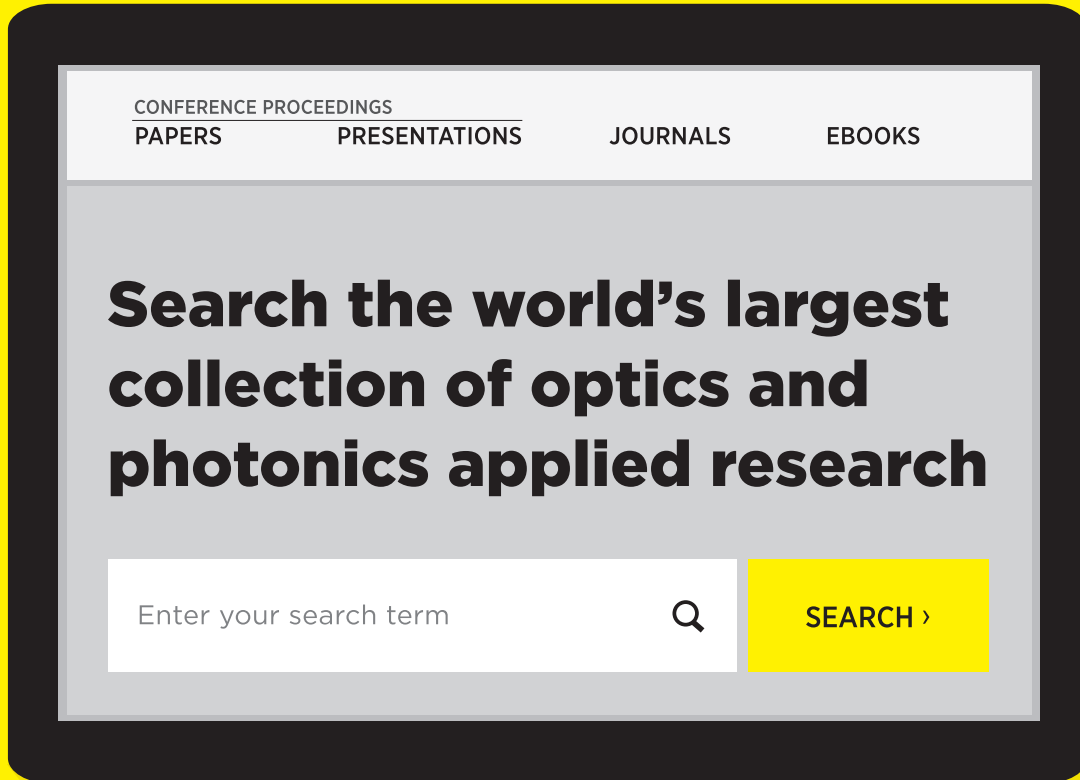

New Platform:

- » Enhanced usability
- » Improved search functionality
- » Expanded proprietary taxonomy
- » Full-text HTML proceedings and eBooks
- » Presentation recording videos from SPIE conferences
- » Mobile-friendly design

spiedl.org



Plan to attend
**Advanced
Lithography**
2019

The leading event for the lithography community.



Mark your calendar for 24-28 February 2019